

FD 5

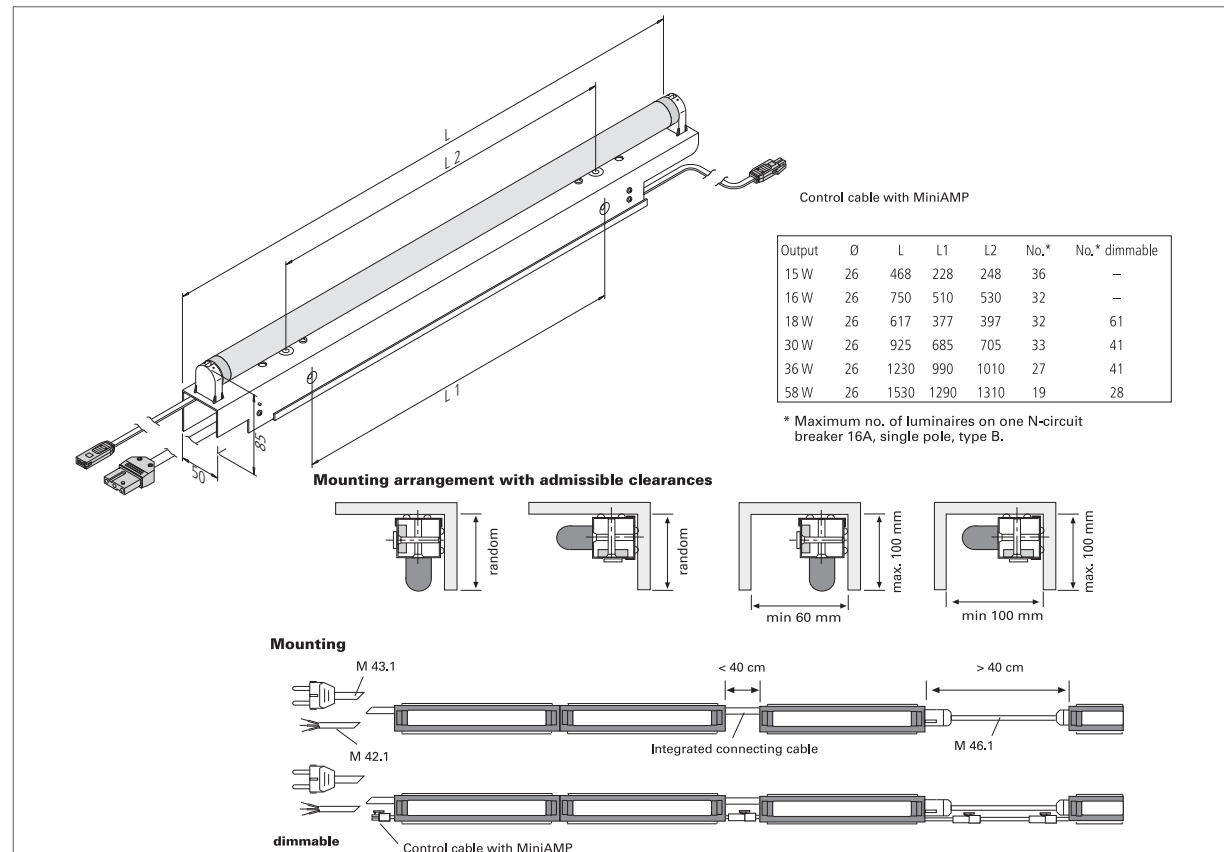

Linear Luminaire with integrated Connecting Cable

- Application:** diffused strip light for direct and indirect lighting in shop-fittings and exhibitions
- Connection:** 220 – 240V / 50 – 60Hz
- Lamp:** extra long-life T8 (ø 26mm) fluorescent lamp, ø life 20,000 hours
- Energy efficiency:** good – very good, 63 – 79lm/W (15 – 58W)
- Colour rendering:** good, Ra = 80 – 89
- Special features:** flicker-free instant start, energy-saving due to an electronic ballast (not dimmable 30-58W: cold start electronic ballast optimised for switching on/off max. 3-4 times a day); dimmable version (1 – 10V) also available; integrated, flexible connection system; for horizontal and vertical mounting.



FD 5

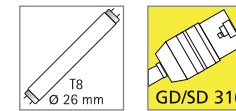
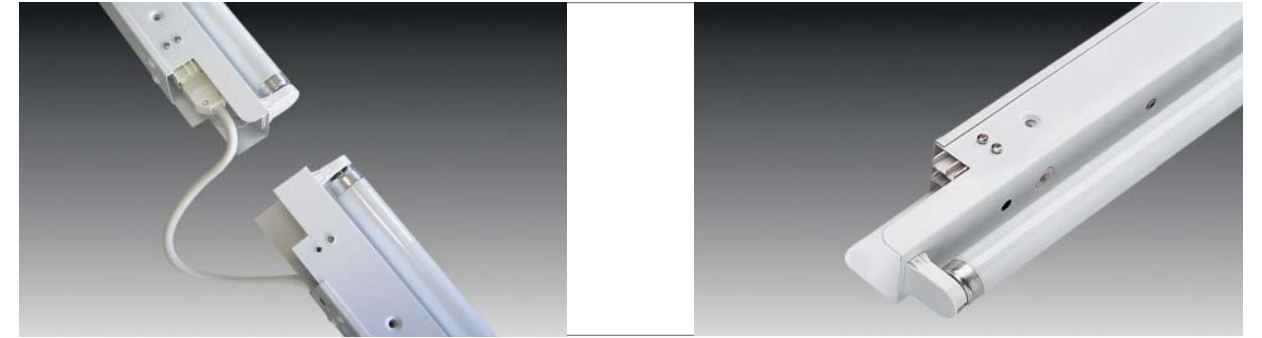

FD 5 – the flexible strip light for direct or indirect illumination. The integrated plug-in system with flexible connecting cable allows variable distances between luminaires of from 0 to 40 cm. Thanks to the through-wiring, light strips are easily viable. The luminaires are available in six lengths from 468 to 1530 mm with output levels from 15 to 58 W.

Article No.	Description	Illustration	Features	Approx. weight
501 071 301 00	FD 5 468mm 15W		<ul style="list-style-type: none"> • please order T8 lamp (page 143) separately • incl. electronic ballast 	750 g
501 071 303 00	FD 5 620mm 18W			1000 g
501 071 302 00	FD 5 750mm 16W			1100 g
501 071 304 00	FD 5 925mm 30W			1500 g
501 071 305 00	FD 5 1230mm 36W			1950 g
501 071 306 00	FD 5 1530mm 58W			2300 g
501 070 902 02	FD 5 620mm 18W dimmable (1-10V)		<ul style="list-style-type: none"> • please order T8 lamp (page 143) separately • incl. electronic ballast • dimmable (1 – 10V) • Dimmer (page 138) 	1250 g
501 070 903 00	FD 5 925mm 30W dimmable (1-10V)			1650 g
501 070 904 02	FD 5 1230mm 36W dimmable (1-10V)			2100 g
501 070 905 00	FD 5 1530mm 58W dimmable (1-10V)			2450 g
501 071 202 00	FD 5 620mm 18W dimmable (DALI)			1250 g
501 071 203 00	FD 5 925mm 30W dimmable (DALI)			1650 g
501 071 204 00	FD 5 1230mm 36W dimmable (DALI)	2100 g		
501 071 205 00	FD 5 1530mm 58W dimmable (DALI)	2450 g		
215 100 105 01	M42.1/ 500 mains cable 0.5m		<ul style="list-style-type: none"> • with ferrules 	70 g
215 100 102 01	M42.1/1000 mains cable 1m			120 g
215 100 103 01	M42.1/1500 mains cable 1.5m			170 g
215 100 101 01	M42.1/2000 mains cable 2m			220 g
215 100 104 01	M42.1/3000 mains cable 3m			320 g
215 100 204 01	M43.1/1000 mains cable 1m			170 g
215 100 203 01	M43.1/1500 mains cable 1.5m			220 g
215 100 201 01	M43.1/2000 mains cable 2m			270 g
215 100 202 01	M43.1/3000 mains cable 3m			370 g
215 100 401 01	M46.1/ 200 connecting cable 0.2m			50 g
215 100 404 01	M46.1/ 300 connecting cable 0.3m	60 g		
215 100 402 01	M46.1/ 500 connecting cable 0.5m	80 g		
215 100 403 01	M46.1/1000 connecting cable 1m	130 g		
215 100 405 01	M46.1/1500 connecting cable 1.5m	180 g		
215 100 406 01	M46.1/2000 connecting cable 2m	230 g		
215 100 407 01	M46.1/3000 connecting cable 3m	320 g		
502 004 000 04	G 316 M socket		<ul style="list-style-type: none"> • mountable 	25 g
502 005 000 04	S 316 M plug			25 g

further information on page 132