

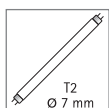

## Glass Shelf Light

- Application:** lighting solution with exceptional visual impact for the home, business and office
- Connection:** 230 – 240V / 50 – 60Hz
- Lamp:** long-life T2 (ø 7mm) fluorescent lamp, ø life 8,000 hours
- Energy efficiency:** good – very good, 68 – 72lm/W (11 – 13W)
- Colour rendering:** satisfactory, Ra = 70 – 79
- Special features:** flicker-free instant start and energy-saving with integrated electronic ballast; 8mm tempered safety glass for loads up to 10kg; easy to adjust with knurled screws.

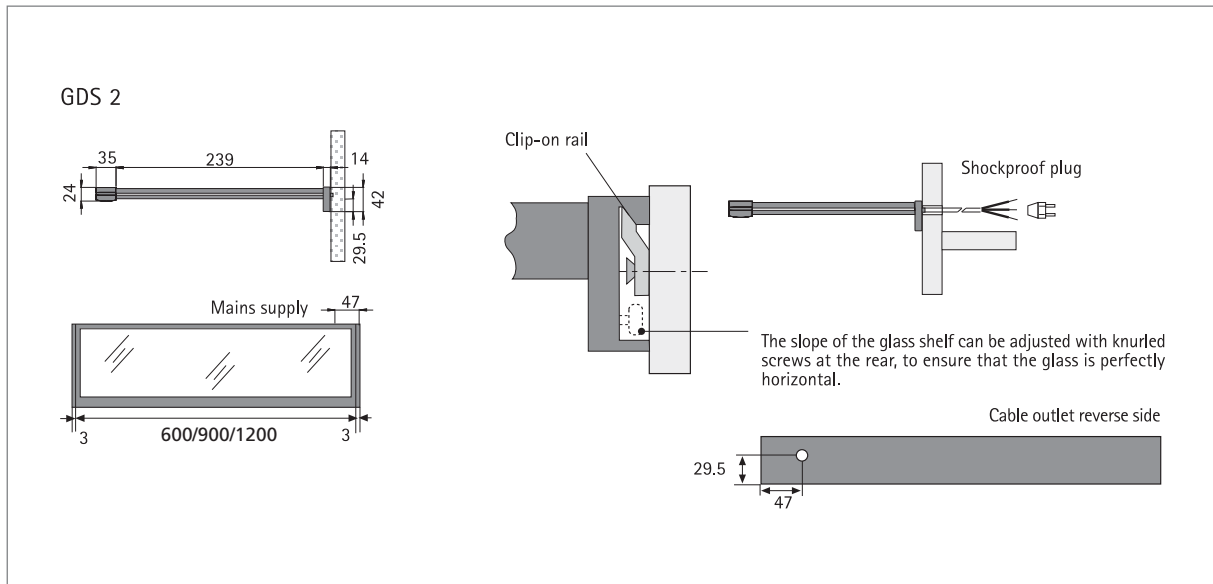

GDS – the quality lighting system in a glass shelf. The reflections of light in the glass prove to be a real eye-catcher both at home and in the office. In a business environment products are shown off to their best advantage – the perfect combination of function and style. T2 lamp and mains cable included.

Article No.	Description	Features	Approx. weight
501 420 201 12	GDS 2 600mm 1x13W	<ul style="list-style-type: none"> <li>stainless steel look</li> <li>Mains cable with shockproof plug D/F/B supplied loose</li> </ul>	3700 g
501 420 202 12	GDS 2 900mm 2x11W	<ul style="list-style-type: none"> <li>incl. T2 lamp cw (cool white)</li> <li>incl. electronic ballast</li> </ul>	5500 g
501 420 203 12	GDS 2 1200mm 2x13W	<ul style="list-style-type: none"> <li>8mm satinised tempered safety glass</li> </ul>	7200 g