

LED Floor

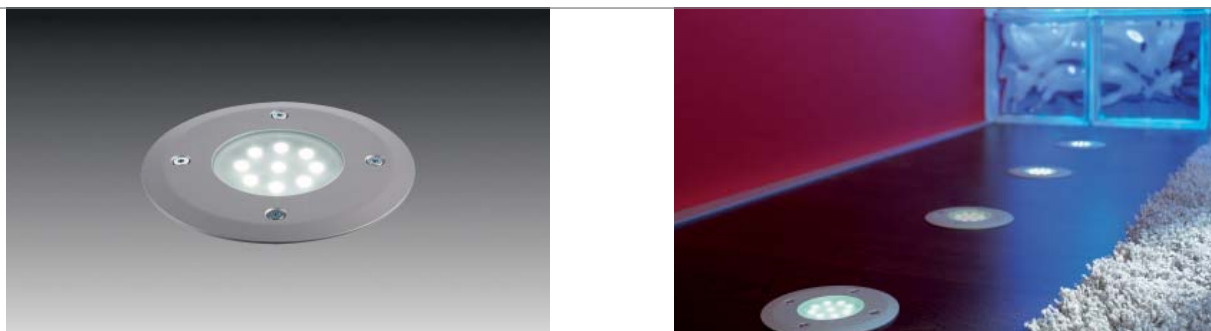

Extra Flat LED Recessed Floor Light

- Application:** special lighting solution for floors in homes and businesses
- Connection:** LED-transformer DC 24V
- Lamp:** extremely long-life 9 x 0.1W LEDs, \varnothing life 50,000 hours
- Energy efficiency:** satisfactory, 10lm/W (cw)
- Colour rendering:** satisfactory, Ra = 70,
- Special features:** recessed in laminated floors and timber floors (only 7mm recess depth); chemically tempered 3mm glass cover capable of bearing up to 200kg; casing with anodised aluminium decor ring; the luminaires can be connected in rows using connecting cable (no radial wiring needed); dimmer as an optional extra.

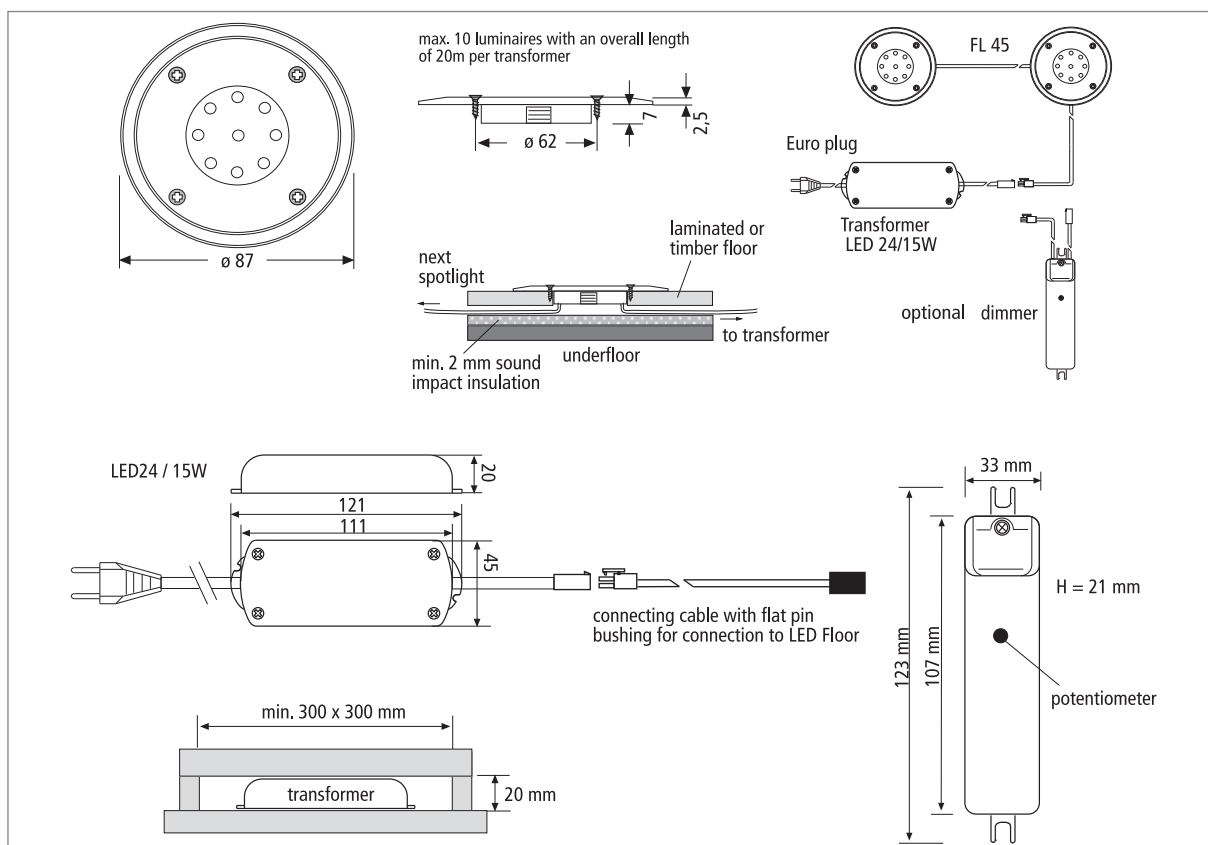



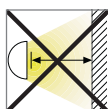
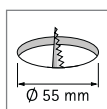

LED Floor

Fluorescent
Halogen
LED



no minimum
clearance

LED Floor – the lighting system for atmospheric accents. For laminated or timber floors. Diffused illumination without UV rays. Modern recessed luminaire for highlighting walls, furniture or architectural features.

Article No.	Description	Illustration	Features	Approx. weight
610 010 210 17	LED Floor 1W anodised aluminium		<ul style="list-style-type: none"> light colour cw (cool white) 	60 g
215 240 505 01	FL 45 connecting cable 0.5m			5 g
215 240 510 01	FL 45 connecting cable 1m		10 g	
215 240 520 01	FL 45 connecting cable 2m		20 g	
615 003 007 03	Transformer LED24/15W with 2m connecting cable to first luminaire		<ul style="list-style-type: none"> mains cable 2m with Euro plug 	160 g
506 180 101 01	Dimmer LED Floor with connecting cables 0.2m		<ul style="list-style-type: none"> is connected between transformer and 1st LED Floor 	65 g