

LED Interior Cabinet Luminaire SIL-LED



Hera[®]
Light Years Ahead.



LED Interior Cabinet Luminaire

- Application:** flat cabinet lighting for kitchens, bedrooms and living areas
Connection: LED transformer DC 24V
Lamp: extremely long-life 70 mW LED, \varnothing life 30,000 hours
Energy efficiency: good, 50lm/W
Colour rendering: good, Ra = 80
Special features: integrated touch-less sensor switch; screw-on bracket as accessory for side fixture in drawers.

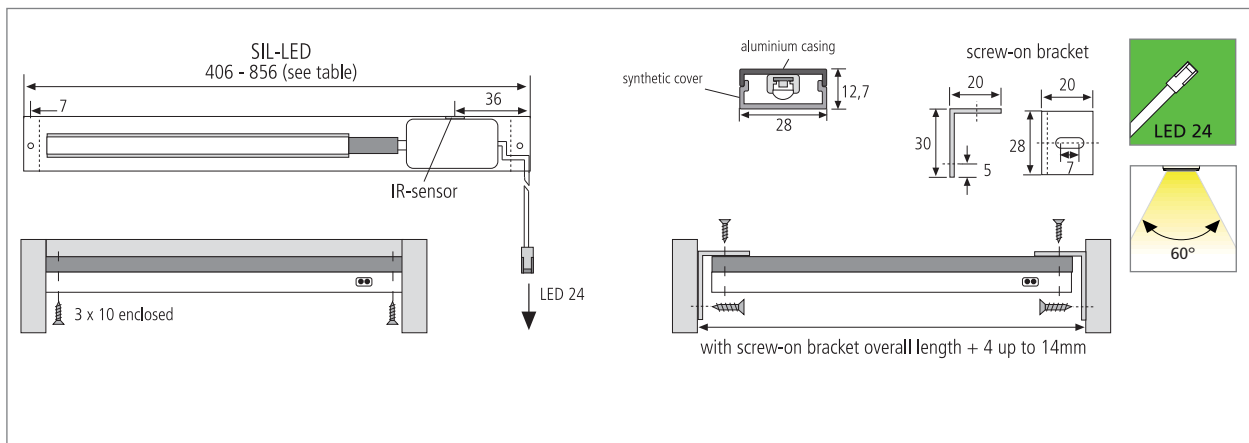

Article-No.	Description	Illustration	Features	Approx. weight
610 012 101 01	SIL-LED 2,4W 406mm (with screw-on bracket 410-420mm)		<ul style="list-style-type: none"> mains cable 2,5m with LED 24 plug anodised aluminium light colour cw (cool white) 	110 g
610 012 102 01	SIL-LED 3,2W 556mm (with screw-on bracket 560-570mm)			170 g
610 012 103 01	SIL-LED 5,6W 856mm (with screw-on bracket 860-870mm)			290 g
202 040 110 01	Screw-on bracket SIL-LED for side mounting		<ul style="list-style-type: none"> variabel zu montieren (overall length + 4 up to 14mm) 	20 g
206 040 011 01	Transformer LED 24/15W DC 24V 12-way distributor		<ul style="list-style-type: none"> mains cable 2m with Euro plug 	167 g